

SR-50 | Stone reomover + STRC-5 | Outfeed conveyoyr
 SR-50 | Steintrenner + STRC-5 | Stabkettenaustrageband

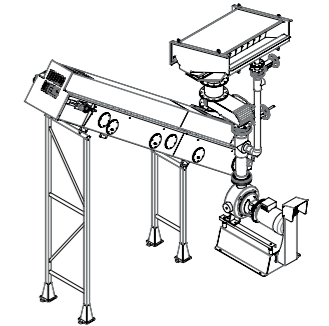
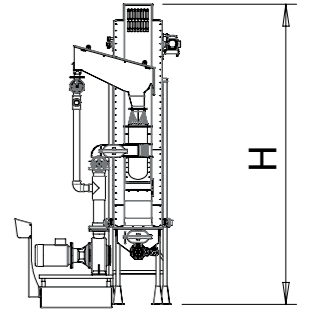
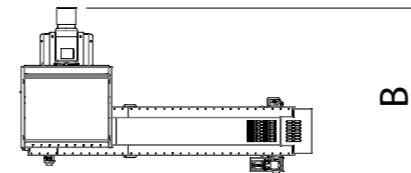
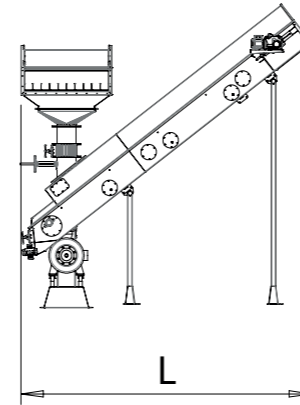
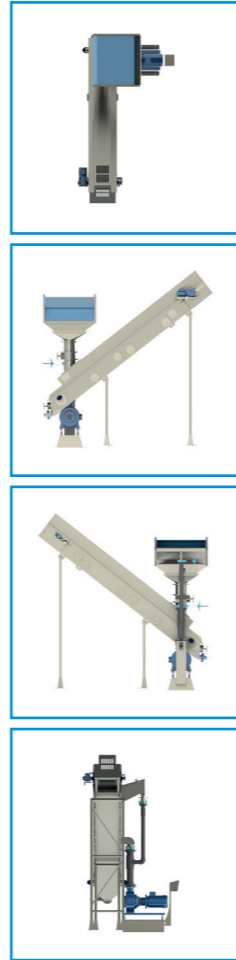

SR-50	Stone remover with outfeed conveyoyr
Intended use	Suitable to separate the product of stones and clods
Products	Carrots, potatoes, beetroot and other products

Description Stones and clods of product separated and discharged by a outfeed conveyoyr.

Standard equipment

- Solid stainless steel construction in flow-optimized form
- PVC sheet
- Stone reomover belt
- Connection flange for pump
- Pump
- Piping system
- Flume
- Safe for users, CE compliant
- HACCP standard

Specifications

- Width (B): 4130 mm
- Lenght (L): 2350 mm
- Height (H) : 4270 mm
- Power supply: 230/400 VAC+N+PE, 50 Hz
- Pump: 11.0 KW
- Potatoes capacity: 40.0 up to 50.0 t/h
- Carrots capacity: 20.0 up to 25.0 t/h

Possible combinations

- Soak tank
- Drum washer

SR-50	Steintrenner mit Stabkettenaustrageband
Best. Verwendung	Geeignet zum Trennen des Produktes von Steinen und Erdklumpen
Produkte	Karotten, Kartoffeln, rote Beete und ähnliche Produkte

Beschreibung Steine und Erdklumpen vom Produkt getrennt und über eine Stabkettenaustrageband ausgetragen.

Serienausstattung

- Solide Konstruktion aus rostfreiem Stahl
- PVC Bremstuch
- Steinaustrageband
- Anschlussflansch für Pumpe
- Druckpumpe
- Rohrleitung
- Schwemmrinne
- Sicher für den Benutzer, CE konform
- HACCP standard

Technische Daten

- Breite (B): 4130 mm
- Länge (L): 2350 mm
- Höhe (H) : 4270 mm
- Elektrischer Anschluß: 230/400 VAC+N+PE, 50 Hz
- Pumpe: 11.0 KW
- Kartoffeln Leistung: 40.0 bis 50.0 t/h
- Karotten Leistung: 20.0 bis 25.0 t/h

Kombinationsmöglichkeit

- Vorweichtank
- Trommelwaschmaschine